

Eco-Pure Peat Moss Biofilter

Simply Natural, Naturally Simple

Peat Biofilter Direct Drainage

Part Number: PBF4-DD



The Eco-Pure Peat Moss Biofilter was designed for extreme site conditions and sensitive environments. The system utilizes a specific blend of sphagnum peat moss for the treatment of septic tank effluent.

Sphagnum peat moss provides a well-balanced eco-system of naturally occurring organisms that digest the harmful pollutants contained in the wastewater stream. The system replicates the same process that occurs in nature.

During installation, pre-packaged sphagnum peat moss pillows are placed within our proprietary polyethylene module. One Eco-Pure module can treat the wastewater from up to a four bedroom home. The modules can be linked together for larger wastewater flows.

The unique properties of sphagnum peat moss allow our system to operate without expensive air blowers or compressors. In addition, the system was designed to be gravity-fed. Depending on site conditions, dosing pumps may not be necessary. This provides additional cost savings compared to other systems.

Extensive university research, independent third-party testing and real world experience have demonstrated that the Eco-Pure Peat Moss Biofilter will protect the most sensitive environments.



Pad Installation

Applications

- Single Family Homes
- Multi-Family Homes
- Apartment Complexes
- Churches
- Office Buildings
- Restaurants
- Seasonal Use Homes
- Water-Front Homes
- Small Lots
- High Groundwater

Features and Benefits

- Designed to drain directly on top of a pad system
- 14, 3/4" drainage holes are factory installed
- **No outlet piping required**
- Can cost much less than other treatment systems
- The system can be completely passive
 - No Electricity Needed
 - No Moving Parts
 - No Dosing Pumps Needed
- Ease of Installation
- Lowest Cost of Operation
 - No Costly Blowers to Replace
 - No Excess Sludge Removal
- Low Cost of Maintenance
- Ease of Maintenance
- Low profile, great for high water table
 - Will not float
- Great For Seasonal Use Homes
 - No ramp up time
 - No shut down procedures

Design Procedures

The Eco-Pure Peat Moss Biofilter must be designed per the Eco-Pure Design, Installation and Maintenance Guide, January, 2010. All systems incorporating the Eco-Pure Peat Moss Biofilter must be designed by a state registered Professional Engineer or a state approved system designer.

Installation Procedures

The Eco-Pure Peat Moss Biofilter must be installed per the manufacturer's Installation Guide, January, 2010. Only factory trained personnel may install the Eco-Pure Peat Moss Biofilter.

Maintenance Procedures

Routine inspection and maintenance must take place at least once per year. Maintenance must be performed per the Eco-Pure Maintenance Manual, January, 2010. Only factory trained personnel may perform maintenance.

Please refer to your state and/or local onsite wastewater treatment and disposal regulations for details pertaining to your systems design, installation and maintenance requirements.

Cross Section View

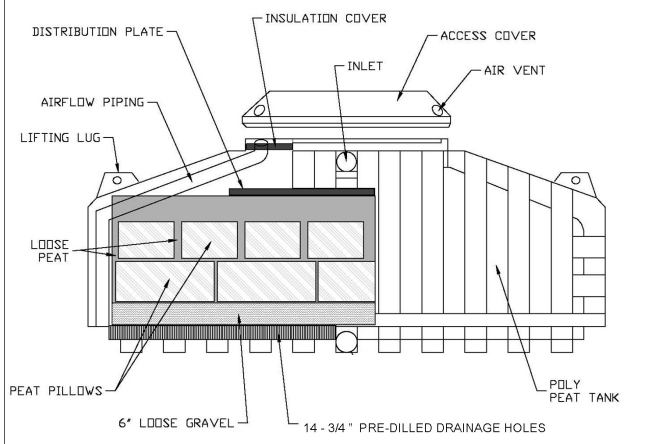

Outline Dimensions

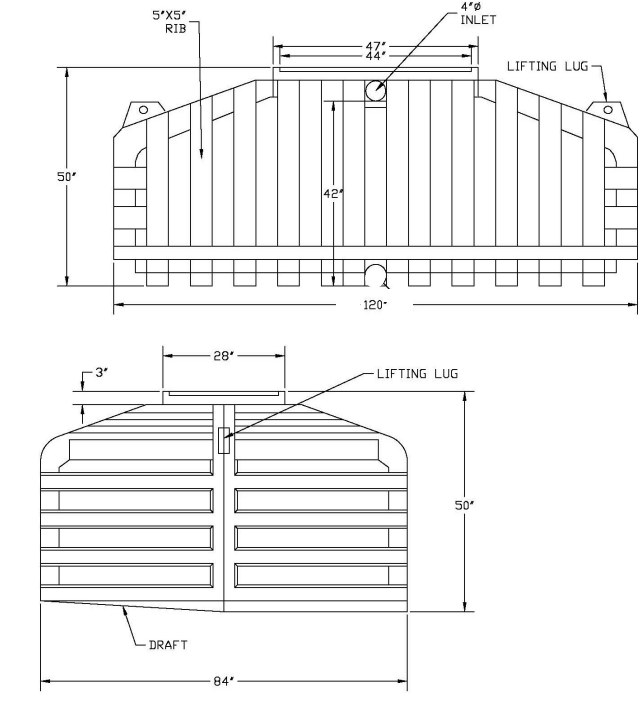

Ordering Information

Part Number	PBF4-DD
-------------	---------

Dimensions

Length	Width	Height
120"	84"	50"

Treatment Capacity

Parameter	Capacity
GPD ⁽¹⁾	650 maximum peak flow
BOD5 ⁽²⁾	240 mg/L

(1) One module for up to a 4 bedroom home

(2) Wastewater described as residential strength waste

Eco-Pure Peat Moss Biofilter Component Materials

Quantity	Description
1	Polyethylene Module and Cover
1	Insulation Cover
41	Sphagnum Peat Moss Pillows
10	Sphagnum Peat Moss Bags
1	Polyethylene Distribution Plate
1	4" x 2" Inlet Pipe Assembly
2	4" Vent Pipes

In order to provide the best product possible, specifications and requirements are subject to change.

Patent #: US 6,620,321 B2

PBF4-DDSS (1/11)

PBF4-DD Pad Disposal Top View

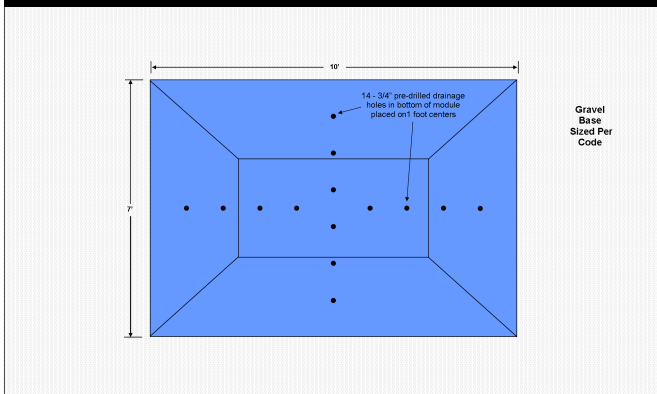

Made In The USA

